

MOLD ALIGNMENT

Guide Locks.....	D12
Multi-Plate Locks.....	D14
Radius Top Locks - Black & Gold.....	D7
Radius Top Locks - Black & Silver.....	D5
Shoulder Plates for Tapered Interlocks.....	D16
Shuttle Mold Side Locks.....	D11
Shuttle Mold Top Locks.....	D4
Side Locks.....	D10
Tapered Bar Locks.....	D13
Tapered Round Interlocks.....	D15
Top Locks - Black & Gold.....	D6
Top Locks - Black & Silver.....	D3
Tri-Side Locks.....	D8
Tri-Lock Top Locks.....	D9

Our family of mold locks include more than ten different styles. PCS locks are easily installed and provide a dependable, smooth acting, long lasting locking system.

- Top Locks
- Tri-Locks
- Side-Locks
- Guide Locks
- Tapered Bar Locks
- Multi-Plate Locks
- Tapered Round Interlocks
- Shoulder Plates



Top Locks - Black & Silver

- Thickness is relieved on male insert past the parting line
- Armor Coating provides increased lubricity
- Female inserts are notched for easy removal
- Exposed edges chamfered
- Grease grooves present on male insert

PCS Top Locks provide positive alignment between mold halves. These locks are hardened and precision ground to assure complete interchangeability. The lubricious properties of Armor Coating treatment combined with the qualities of graphitic tool steel provide a dependable, smooth acting, long lasting locking system.



SPECIFICATIONS

Chamfered Edges	Yes
Female Material Type	8620
Female Coating/Finish	Armor Coating
Female Coating/Finish Hardness	70 - 72 Rc
Female Hardness	54 - 58 Rc
Male Material Type	Hot Work Tool Steel
Male Coating/Finish	Black Oxide
Male Hardness	52 - 56 Rc
Unit of Measure	Inch

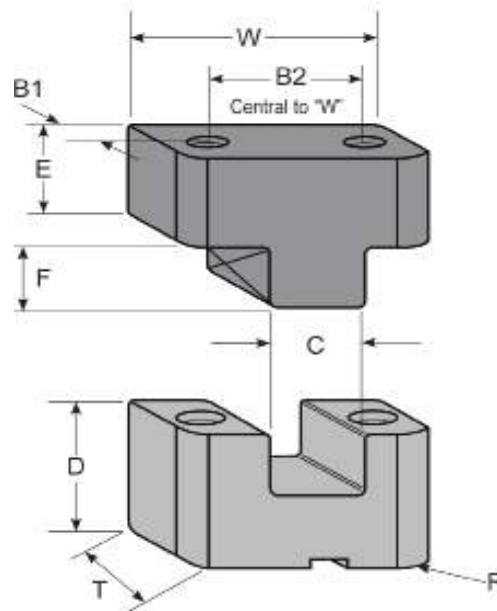

All holes are machined to (B) location

CATALOG NO.	W +.0000 -.0004	T +.000 -.002	F +.000 -.010	OVERALL HEIGHT	C +.000 -.010	B1 +.010 -.010	B2 +.010 -.010	D +.000 -.002	R +.010 -.000	E +.000 -.002	SHCS MALE	SHCS FEMALE
TL-100	1.0000	.500	.275	.875	.3750	.250	.688	.500	.187	.375	6-32 x 1/2	6-32 x 5/8
TL-125	1.2500	.625	.375	1.125	.4380	.312	.875	.625	.250	.500	6-32 x 1/2	6-32 x 5/8
TL-150	1.5000	.875	.500	1.625	.5000	.437	1.000	.875	.250	.750	8-32 x 3/4	8-32 x 3/4
TL-200	2.0000	1.000	.625	1.875	.7500	.500	1.375	1.125	.375	.750	10-32 x 3/4	10-32 x 1
TL-300	3.0000	1.125	.75	2.25	1.1250	.562	2.250	1.500	.500	.750	1/4-20 x 3/4	1/4-20 x 1-1/2



Shuttle Mold Top Locks

- Dimensionally checked and packaged as a precision matched set
- Thickness is relieved on male insert past the parting line
- Armor Coating coating provides increased lubricity
- Female inserts are notched for easy removal
- Exposed edges chamfered
- Grease grooves present on male insert

Shuttle Mold Top Locks come standard with two female halves and one male half. PCS Top Locks provide positive alignment between mold halves. These locks are hardened and precision ground to assure complete interchangeability. The lubricious properties of Armor Coating treatment combined with the qualities of graphitic tool steel provide a dependable, smooth acting, long lasting locking system.

SPECIFICATIONS

Chamfered Edges	Yes
Female Material Type	8620
Female Coating/Finish	Armor Coating
Female Coating/Finish Hardness	70 - 72 Rc
Female Hardness	54 - 58 Rc
Male Material Type	Hot Work Tool Steel
Male Coating/Finish	Black Oxide
Male Hardness	52 - 56 Rc
Unit of Measure	Inch

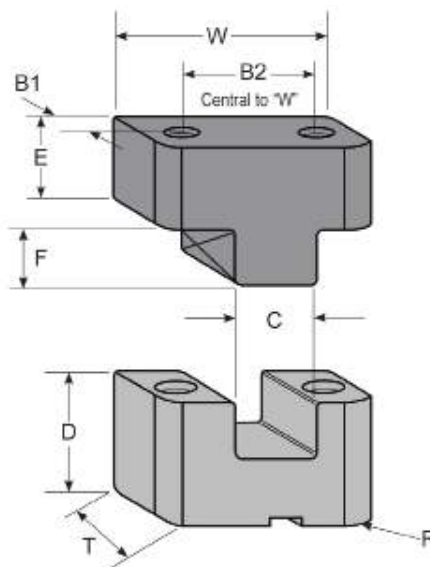

All holes are machined to (B) location

CATALOG NO.	W +.0000 -.0004	T +.000 -.002	F +.000 -.010	OVERALL HEIGHT	C .0002 TOTAL	B1 +.010 -.010	B2 +.010 -.010	D +.000 -.002	R +.010 -.000	E +.000 -.002	SHCS MALE	SHCS FEMALE
STL-100	1.0000	.500	.275	.875	.3750	.250	.688	.500	.187	.375	6-32 x 1/2	6-32 x 5/8
STL-125	1.2500	.625	.375	1.125	.4380	.312	.875	.625	.250	.500	6-32 x 1/2	6-32 x 5/8
STL-150	1.5000	.875	.500	1.625	.5000	.437	1.000	.875	.250	.750	8-32 x 3/4	8-32 x 3/4
STL-200	2.0000	1.000	.625	1.875	.7500	.500	1.375	1.125	.375	.750	10-32 x 3/4	10-32 x 3/4
STL-300	3.0000	1.125	.750	2.250	1.125	.562	2.250	1.500	.500	.750	1/4-20 x 3/4	1/4-20 x 1-1/2

Radius Top Locks - Black & Silver

- Thickness is relieved on male insert past the parting line
- Armor Coating coating provides increased lubricity
- Female inserts are notched for easy removal
- Exposed edges chamfered
- Grease grooves present on male insert
- Radius on all four corners



PCS Radius Top Locks provide positive alignment between mold halves and come standard with dual radii which allows for them to be mounted internally. These locks are hardened and precision ground to assure complete interchangeability. The lubricious properties of Armor Coating treatment combined with the qualities of graphitic tool steel provide a dependable, smooth acting, long lasting locking system.

SPECIFICATIONS	
Chamfered Edges	Yes
Female Material Type	8620
Female Coating/Finish	Armor Coating
Female Coating/Finish Hardness	70 - 72 Rc
Female Hardness	54 - 58 Rc
Male Material Type	Hot Work Tool Steel
Male Coating/Finish	Black Oxide
Male Hardness	52 - 56 Rc
Unit of Measure	Inch

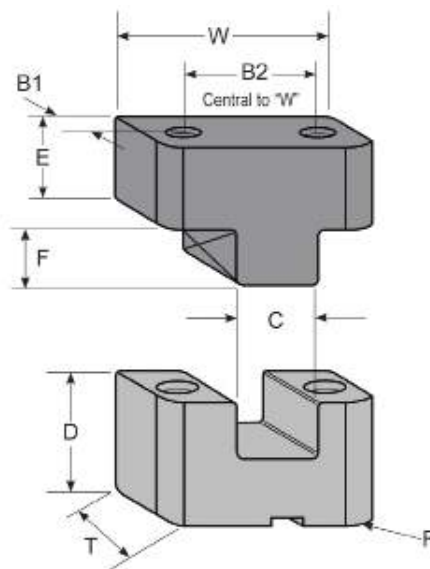

All holes are machined to (B) location

CATALOG NO.	W +.0000 -.0004	T +.000 -.002	F +.000 -.010	OVERALL HEIGHT	C .0002 Total	B1 +.010 -.010	B2 +.010 -.010	D +.000 -.002	R +.010 -.000	E +.000 -.002	SHCS MALE	SHCS FEMALE
TL-100R	1.0000	.500	.275	.875	.3750	.250	.688	.500	.187	.375	6-32 x 1/2	6-32 x 1/2
TL-125R	1.2500	.625	.375	1.125	.4380	.312	.875	.625	.250	.500	6-32 x 5/8	6-32 x 5/8
TL-150R	1.5000	.875	.500	1.625	.5000	.437	1.000	.875	.250	.750	8-32 x 7/8	8-32 x 7/8
TL-200R	2.0000	1.000	.625	1.875	.7500	.500	1.375	1.125	.375	.750	10-32 x 7/8	10-32 x 7/8
TL-300R	3.0000	1.125	.75	2.250	1.1250	.562	2.250	1.500	.500	.750	1/4-20 x 7/8	1/4-20 x 7/8

Top Locks - Black and Gold



- Thickness is relieved on male insert past the parting line
- Female inserts are notched for easy removal
- Exposed edges chamfered
- Grease grooves present on male insert

PCS Black & Gold Top Locks provide positive alignment between mold halves and are priced well below the competition. These locks are hardened and precision ground to assure complete interchangeability.

SPECIFICATIONS	
Female Material Type	A-2
Female Coating/Finish	Titanium Nitride
Female Coating/Finish Hardness	70-72 Rc
Female Hardness	58-65 Rc
Male Material Type	Hot Work Tool Steel
Male Coating/Finish	Melonite
Male Coating/Finish Hardness	80 Rc
Male Hardness	40-44 Rc
Unit of Measure	Inch

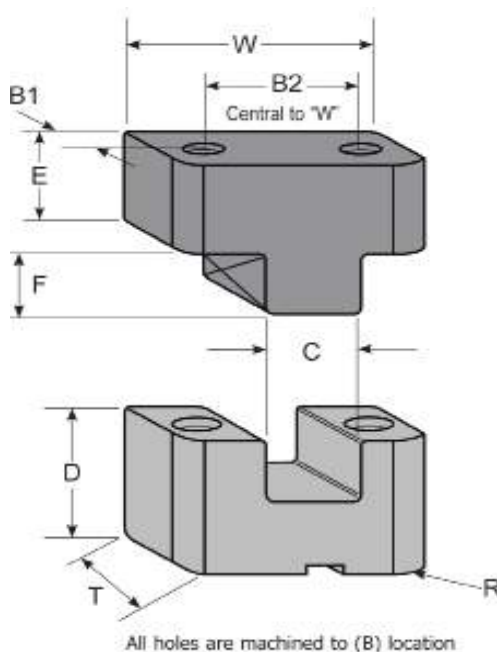

CATALOG NO.	W +.0000 -.0004	T +.000 -.002	F +.000 -.010	OVERALL HEIGHT	C .0002	B1 +-.010	B2 +-.010	D +.000 -.002	R +.010 -.000	E +.000 -.002	SHCS MALE	SHCS FEMALE
TL-125P	1.2500	.750	.375	1.125	.4378	.375	.875	.625	.260	.500	8-32 x 5/8	8-32 x 3/4
TL-150P	1.5000	1.000	.500	1.250	.4998	.500	1.000	.875	.260	.375	10-32 x 1/2	10-32 x 1
TL-200P	2.0000	1.125	.500	1.500	.7498	.563	1.375	.875	.385	.625	1/4-20 x 3/4	1/4-20 x 1
TL-250P	2.5000	1.500	.750	2.000	.9998	.750	1.750	1.375	.385	.625	1/4-20 x 3/4	1/4-20 x 1 1/2
TL-300P	3.0000	1.750	.750	2.125	1.1248	.875	2.250	1.250	.510	.875	5/16-18 x 1	5/16-18 x 1-1/4

Radius Top Locks - Black and Gold

- Thickness is relieved on male insert past the parting line
- Female inserts are notched for easy removal
- Exposed edges chamfered
- Grease grooves present on male insert
- Radius on all four corners

PCS Black & Gold Radius Top Locks come standard with dual radii which allows for them to be mounted internally. These locks provide positive alignment between mold halves and are priced well below the competition. These locks are hardened and precision ground to assure complete interchangeability.



SPECIFICATIONS	
Female Material Type	A-2
Female Coating/Finish	Titanium Nitrided
Female Coating/Finish Hardness	70-72 Rc
Female Hardness	58-65 Rc
Male Material Type	Hot Work Tool Steel
Male Coating/Finish	Melonite
Male Coating/Finish Hardness	80 Rc
Male Hardness	40-44 Rc
Unit of Measure	Inch

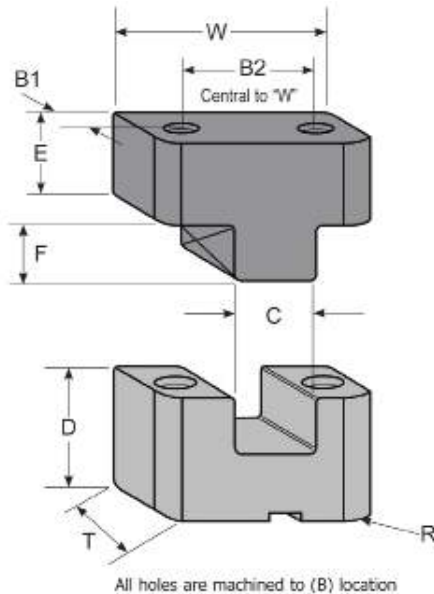

CATALOG NO.	W +.0000 -.0004	T +.000 -.002	F +.000 -.010	OVERALL HEIGHT	C .0002	B1 +.010	B2 +.010	D +.000 -.002	R +.010 -.000	E +.000 -.002	SHCS MALE	SHCS FEMALE
TL-125PR	1.2500	.750	.375	1.125	.4378	.375	.875	.625	.260	.500	8-32 x 5/8	8-32 x 3/4
TL-150PR	1.5000	1.000	.500	1.250	.4998	.500	1.000	.875	.260	.375	10-32 x 1/2	10-32 x 1
TL-200PR	2.0000	1.125	.500	1.500	.7498	.563	1.375	.875	.385	.625	1/4-20 x 3/4	1/4-20 x 1
TL-250PR	2.5000	1.500	.750	2.000	.9998	.750	1.750	1.375	.385	.625	1/4-20 x 3/4	1/4-20 x 1 1/2
TL-300PR	3.0000	1.750	.750	2.125	1.1248	.875	2.250	1.250	.750	.875	5/16-18 x 1	5/16-18 x 1-1/4

Tri-Side Locks



- Combines roller, straight and taper lock technologies
- Large roller bearings eliminate galling
- 5° taper guarantees zero tolerance positioning
- Stainless steel retainer
- Black oxide surface finish
- SHCS Included

PCS Tri-Locks combine roller, straight and taper lock technologies. The use of large roller bearings eliminates galling during initial alignment. The 5° tapered interlock guarantees zero tolerance positioning. PCS Tri-Locks have three times more locking contact than standard industry locks.

SPECIFICATIONS

Female Material Type	A-2
Female Coating/Finish	Black Oxide
Female Hardness	58 - 60 Rc
Male Material Type	A-2
Male Coating/Finish	Black Oxide
Male Hardness	58 - 60 Rc
Unit of Measure	Inch

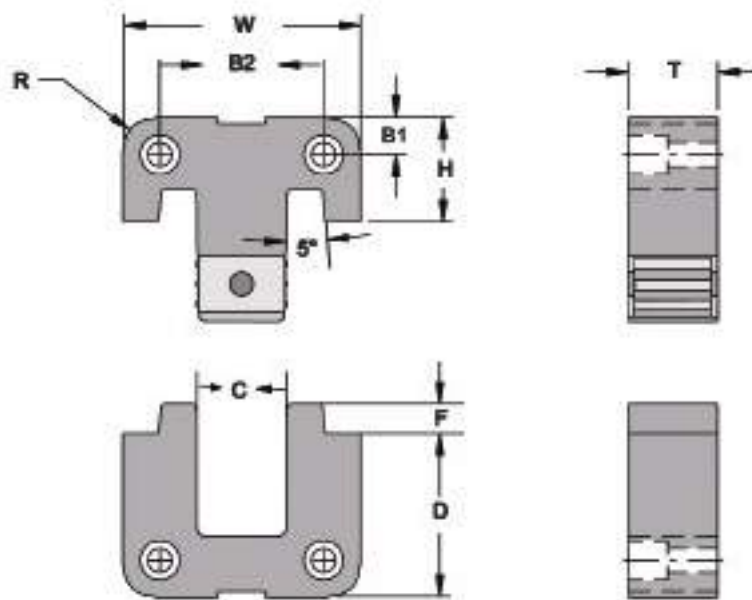

CATALOG NO.	W +.0000 -.0004	T +.002 -.002	C +.0002 -.0002	H +.0000 -.0002	F +.010 -.010	OVERALL HEIGHT	B1 +.010 -.010	B2 +.010 -.010	D +.0000 -.0002	R .010	E	SHCS FEMALE	SHCS MALE
KSL-150	1.500	.500	.563	.875	.300	1.750	.250	1.000	.875	.187	.450	8/32 x 5/8	8/32 x 5/8
KSL-200S*	2.000	.500	.750	.875	.250	2.240	.312	1.375	1.375	.250	.625	10-32 x 5/8	10-32 x 5/8
KSL-200	2.000	.500	.750	.875	.250	2.250	.312	1.375	1.375	.250	.625	10-32 x 5/8	10-32 x 5/8
KSL-300	3.000	.750	1.000	.875	.480	2.750	.375	2.250	1.875	.250	.675	1/4-20 x 1	1/4-20 x 1

* The "S" suffix indicates that the Tri-Locks are for a Shuttle Mold

Tri-Lock Top Locks

- Combines roller, straight and taper lock technologies
- Large roller bearings eliminate galling
- 5° taper guarantees zero tolerance positioning
- Stainless steel retainer
- Black oxide surface finish
- SHCS Included

PCS Tri-Locks combine roller, straight and taper lock technologies. The use of large roller bearings eliminate galling during initial alignment. The 5° tapered interlock guarantees zero tolerance positioning. PCS Tri-Locks have three times more locking contact than standard industry locks.



SPECIFICATIONS	
Female Material Type	A-2
Female Coating/Finish	Black Oxide
Female Hardness	58 - 60 Rc
Male Material Type	A-2
Male Coating/Finish	Black Oxide
Male Hardness	58 - 60 Rc
Unit of Measure	Inch

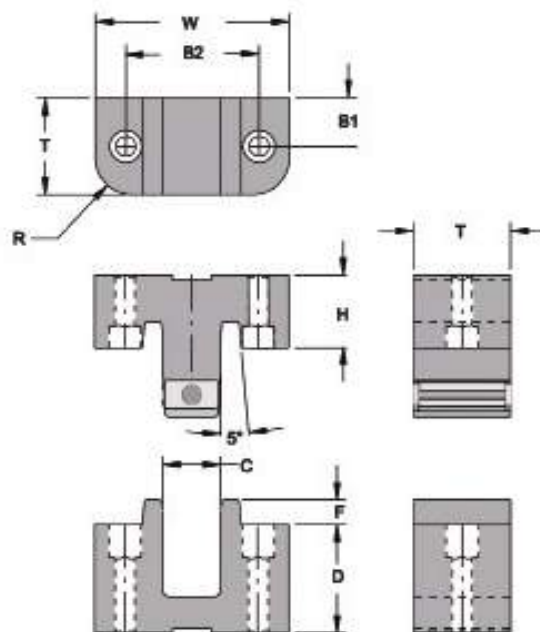

CATALOG NO.	W +.0000 -.0004	T +.002 -.002	C +.0002 -.0002	H +.0000 -.0002	F +.010 -.010	OVERALL HEIGHT	B1 +.010 -.010	B2 +.010 -.010	D +.0000 -.0002	R .010	E	SHCS FEMALE	SHCS MALE
KTL-200	2.000	1.000	.600	.750	.250	1.875	.500	1.375	1.125	.375	.525	10-32 x 1-1/4	10-32 x 3/4
KTL-300	3.000	1.125	1.000	.750	.380	2.250	.562	2.250	1.500	.500	.675	1/4-20 x 1-1/2	1/4-20 x 3/4
KTL-300S*	3.000	1.125	1.000	.750	.380	2.250	.562	2.250	1.500	.500	.675	1/4-20 x 1-1/2	1/4-20 x 3/4

* The "S" suffix indicates that the Tri-Locks are for a Shuttle Mold

Side Locks



- Thickness is relieved on male insert past the parting line
- Armor Coating coating provides increased lubricity
- Female inserts are notched for easy removal
- Exposed edges chamfered
- Grease grooves present on male insert

PCS Side Locks provide positive alignment between mold halves. These locks are hardened and precision ground to assure complete interchangeability. The lubricious properties of Armor Coating treatment combined with the qualities of graphitic tool steel provide a dependable, smooth acting, long lasting locking system.

SPECIFICATIONS	
Female Material Type	8620
Female Coating/Finish	Armor Coating
Female Coating/Finish Hardness	70 - 72 Rc
Female Hardness	54 - 58 Rc
Male Material Type	Hot Work Tool Steel
Male Coating/Finish Hardness	Black Oxide
Male Hardness	52 - 56 Rc
Unit of Measure	Inch

CATALOG NO.	RECOMMENDED MOLD SIZE
PA-100	8x8 - 8x12
PA-125	8x12 - 11x14
PA-150	8x12 - 11x14
PA-200	8x12 - 11x14
PA-300	11x14 - 14x18
PA-400	14x18 - 16x26
PA-500	16x26 - 18x36
PA-600	18x36 or LARGER

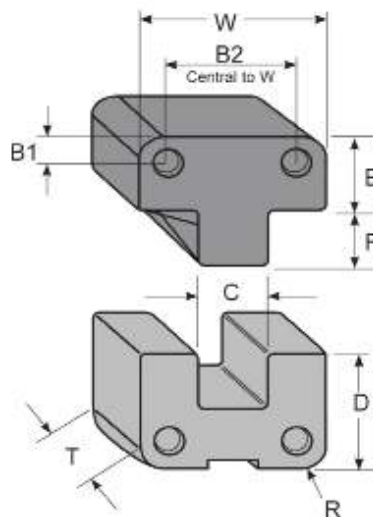

All holes are machined to (B) location

CATALOG NO.	W +.0000 -.0004	T +.000 -.002	F +.000 -.010	OVERALL HEIGHT	C	B1 +.010 -.010	B2 +.010 -.010	D +.000 -.002	R +.010 -.000	E +.000 -.002	SHCS MALE	SHCS FEMALE
PA-100	1.0000	.375	.530	2.000	.500	.250	.500	1.125	.187	.875	10-32 x 1/2	10-32 x 1/2
PA-125	1.2500	.500	.660	2.000	.500	.250	.750	1.125	.187	.875	8-32 x 5/8	8-32 x 5/8
PA-150	1.5000	.500	.560	1.750	.563	.250	1.000	.875	.187	.875	8-32 x 5/8	8-32 x 5/8
PA-200	2.0000	.500	.660	2.250	.750	.312	1.375	1.375	.250	.875	10-32 x 5/8	10-32 x 5/8
PA-300	3.0000	.750	1.13	2.750	1.250	.375	2.250	1.875	.250	.875	1/4-20 x 1	1/4-20 x 1
PA-400	4.0000	1.000	1.13	3.750	1.500	.500	3.000	2.375	.500	1.375	3/8-16 x 1-1/4	3/8-16 x 1-1/4
PA-500	5.0000	1.250	1.63	4.250	2.000	.625	3.750	2.875	.500	1.375	1/2-13 x 1-1/2	1/2-13 x 1-1/2
PA-600	6.0000	1.500	1.63	4.250	2.500	.625	4.750	2.875	.500	1.375	1/2-13 x 1-3/4	1/2-13 x 1-3/4

Shuttle Mold Side Locks

- Dimensionally checked and packaged as a precision matched set
- Thickness is relieved on male insert past the parting line
- Armor Coating coating provides increased lubricity
- Female inserts are notched for easy removal
- Exposed edges chamfered
- Grease grooves present on male insert

PCS Shuttle Mold Side Locks come standard with two female halves and one male half. These locks provide positive alignment between mold halves. These locks are hardened and precision ground to assure complete interchangeability. The lubricious properties of Armor Coating treatment combined with the qualities of graphitic tool steel provide a dependable, smooth acting, long lasting locking system.



SPECIFICATIONS	
Female Material Type	8620
Female Coating/Finish	Armor Coating
Female Coating/Finish Hardness	70 - 72 Rc
Female Hardness	54 - 58 Rc
Male Material Type	Hot Work Tool Steel
Male Coating/Finish	Black Oxide
Male Hardness	50 - 52 Rc
Unit of Measure	Inch

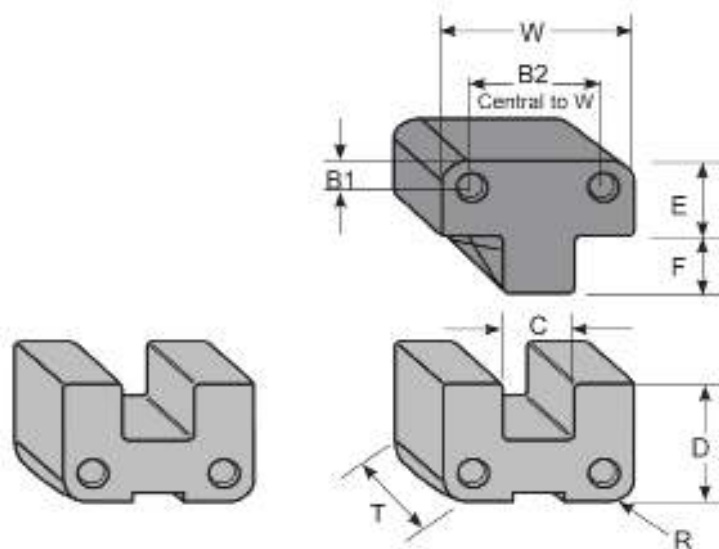

CATALOG NO.	RECOMMENDED MOLD SIZE
SPA-100	8x8 - 8x12
SPA-125	8x12 - 11x14
SPA-150	8x12 - 11x14
SPA-200	8x12 - 11x14
SPA-300	11x14 - 14x18
SPA-400	14x18 - 16x26
SPA-500	16x26 - 18x36

CATALOG NO.	W +.0000 -.0004	T +.000 -.002	F +.000 -.010	OVERALL HEIGHT	C	B1 +.010 -.010	B2 +.010 -.010	D +.000 -.002	R +.010 -.000	E +.000 -.002	SHCS MALE	SHCS FEMALE
SPA-100	1.0000	.375	.530	2.000	.5000	.250	.500	1.125	.187	.875	10-32 x 1/2	10-32 x 1/2
SPA-125	1.2500	.500	.660	2.000	.5000	.250	.750	1.125	.187	.875	8-32 x 5/8	8-32 x 5/8
SPA-150	1.5000	.500	.560	1.750	.5630	.250	1.000	.875	.187	.875	8-32 x 5/8	8-32 x 5/8
SPA-200	2.0000	.500	.660	2.250	.7500	.312	1.375	1.375	.25	.875	10-32 x 5/8	10-32 x 5/8
SPA-300	3.0000	.750	1.130	2.750	1.2500	.375	2.250	1.875	.25	.875	1/4-20 x 1	1/4-20 x 1
SPA-400	4.0000	1.000	1.130	3.750	1.5000	.500	3.000	2.375	.5	1.375	3/8-16 x 1-1/4	3/8-16 x 1-1/4
SPA-500	5.0000	1.250	1.630	4.250	2.0000	.625	3.750	2.875	.5	1.375	1/2-13 x 1-1/2	1/2-13 x 1-1/2

Guide Locks

- Extra long point of engagement
- Provides accurate alignment for molds with interlocking cavities and cores
- Chamfered edges
- Will not bind under unequal mold half thermal expansion
- Armor Coating coating provides increased lubricity



Guide Locks provide positive, accurate alignment for molds with interlocking cavities and cores. The lubricious properties of the Armor Coating treatment combined with the qualities of graphitic tool steel provide a dependable, smooth acting, long lasting locking system.

SPECIFICATIONS

Female Material Type	Hot Work Tool Steel
Female Coating/Finish	Black Oxide
Female Hardness	52 - 56 Rc
Male Material Type	8620
Male Coating/Finish	Armor Coating
Male Coating/Finish Hardness	70 - 72 Rc
Male Hardness	54 - 58 Rc
Unit of Measure	Inch

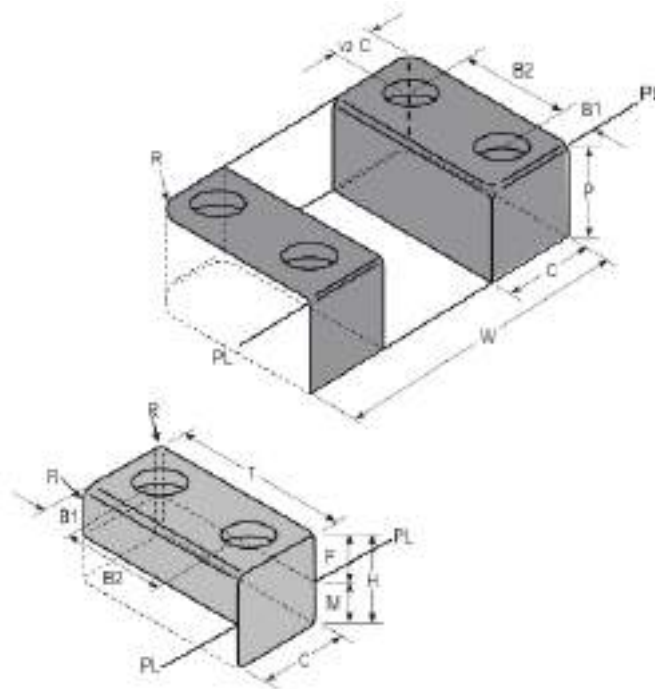

CATALOG NO.	W	T +.000 -.010	H +.000 -.010	F	M	C +.0000 -.0005	B1 +.010 -.010	B2 +.010 -.010	R +.010 -.000	P +.000 -.002	SHCS MALE	SHCS FEMALE
GL-112	1.125	.750	.668	.480	.188	.3750	.200	.350	.125	.500	6-32 x 5/8	6-32 x 1/2
GL-150	1.500	1.000	.855	.605	.250	.5000	.270	.460	.218	.625	10-32 x 3/4	10-32 x 5/8
GL-225	2.250	1.500	1.230	.855	.375	.7500	.344	.812	.250	.875	1/4-20 x 1-1/4	1/4-20 x 7/8
GL-300	3.000	2.000	1.605	1.105	.500	1.0000	.500	1.000	.375	1.125	3/8-16 x 1-1/2	3/8-16 x 1
GL-375	3.750	2.500	1.855	1.355	.500	1.2500	.500	1.500	.375	1.375	3/8-16 x 1-3/4	3/8-16 x 1-1/4

Tapered Bar Locks

- Provides positive alignment between mold halves
- Maintains alignment while allowing for thermal expansion
- Shock resistant S-7 tool steel
- Hardened and precision ground to assure interchangeability

Tapered Bar Locks provide positive alignment between mold halves. These locks are manufactured from S-7 steel and are hardened and precision ground to ensure interchangeability. Tapered Bar Locks maintain alignment of the mold while allowing for thermal expansion.



SPECIFICATIONS	
S Mounting Hole Spread Tolerance	+0.005 / -.005
Material Type	S-7
Hardness	56 - 58 Rc
Unit of Measure	Inch

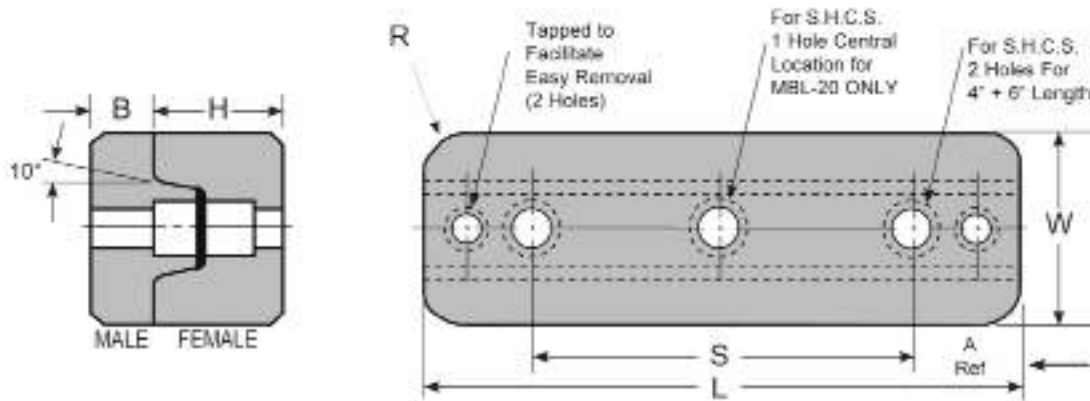

CATALOG NO.		L	W	H	B	R	SHCS MALE	SHCS FEMALE	TAPPED FOR REMOVAL	A REF. MOUNTING HOLE LOCATION FROM EDGE
MALE	FEMALE	+0.010 -0.010	+0.000 -0.001	+0.001 -0.001	+0.001 -0.001	+0.010 -0.000				
MBL-20	FBL-20	1.980	.999	.690	.312	.250	#10 - 24	#10 - 24	1/4 - 20	CTR
MBL-40	FBL-40	3.980	1.249	.870	.375	.312	1/4 - 20	1/4 - 20	1/4 - 20	.74
MBL-60	FBL-60	5.980	1.499	1.000	.500	.375	5/16 - 18	5/16 - 18	5/16 - 18	.99

INSTALLATION INSTRUCTIONS

The mounting pocket in the "A" half of the mold should be accurately aligned with the mounting pocket in the "B" half of the mold. The width of each pocket serves as a precision keyway to maintain the steadfast position of each bar lock. Each pocket must be flat and parallel to the parting line. The mating bar lock should be fit with a slight preload to assure metal to metal contact. The pocket lengths should be long enough to provide clearance.

Multi-Plate Locks

- Provides positive & accurate alignment of mold halves prior to mold closing
- Chamfered edges
- Will not bind under unequal mold half thermal expansion
- Armor Coating coating provides increased lubricity
- Custom Sizes Available Upon Request



Multi-Plate Locks provide positive, accurate alignment of mold halves from 1/2" to 1-5/8" prior to mold closing. The female inserts are notched which allows for easy removal. The lubricious properties of the Armor Coating treatment combined with the qualities of graphitic tool steel provide a dependable, smooth acting, long lasting locking system.

SPECIFICATIONS	
R Corner Radius	.25
R Corner Radius Tolerance	+.010 / -.000
Female Material Type	8620
Female Coating/Finish	Armor Coating
Female Coating/Finish Hardness	70 - 72 Rc
Female Hardness	54 - 58 Rc
Male Material Type	Hot Work Tool Steel
Male Coating/Finish	Black Oxide
Male Hardness	52 - 56 Rc
Unit of Measure	Inch

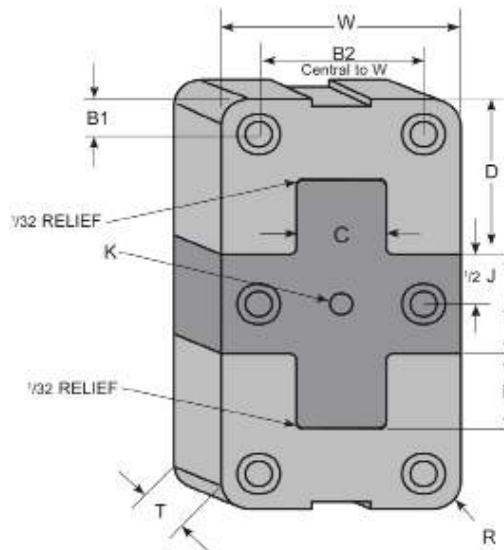

CATALOG NO.	W +.0000 -.0004	T +.000 -.002	C	F +.000 -.010	K SLIP FIT FOR DOWEL	B1 +.010 -.010	B2 +.010 -.010	E +.000 -.004	D +.000 -.002	J +.000 -.004	SHCS MALE	SHCS FEMALE
MPA-287	2.0000	.500	.750	.660	.188	.312	1.375	.875	1.375	.8750	10-32 x 5/8	10-32 x 5/8
MPA-2137	2.0000	.500	.750	.660	.188	.312	1.375	1.375	1.375	1.3750	10-32 x 5/8	10-32 x 5/8
MPA-387	3.0000	.750	1.250	1.130	.251	.375	2.250	.875	1.875	.8750	1/4-20 x 3/4	1/4-20 x 3/4
MPA-3137	3.0000	.750	1.250	1.130	.251	.375	2.250	1.375	1.875	1.3750	1/4-20 x 3/4	1/4-20 x 3/4

Tapered Round Interlocks

- Provides positive alignment between mold halves
- Maintains alignment while allowing for thermal expansion
- Shock resistant S-7 tool steel
- Hardened and precision ground to assure interchangeability
- Shoulder plate required for installation

Tapered Round Locks provide positive alignment between mold halves. These locks are manufactured from S-7 steel and are hardened and precision ground to ensure interchangeability. Tapered Round Locks maintain alignment of mold while allowing for thermal expansion.



SPECIFICATIONS	
M Male Insert Base Height Tolerance	+0.015 / +0.020
Female Material Type	S-7
Female Hardness	56 - 58 Rc
Male Material Type	S-7
Male Hardness	56 - 58 Rc
Unit of Measure	Inch

See page D16 for
Shoulder Plate
Information

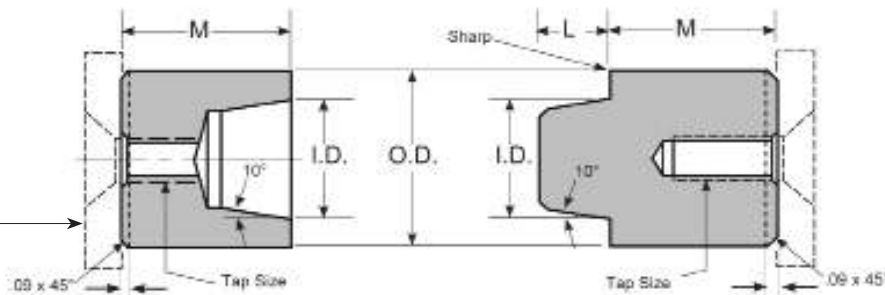

CATALOG NO.		O.D. +.0000 / -.0005	I.D. +/- .0005	M MALE INSERT BASE HEIGHT	THREAD SIZE
MALE	FEMALE				
MR-051	FR-051	.5000	.312	.875	10-24
MR-052	FR-052			1.187	
MR-053	FR-053			1.375	
MR-071	FR-071	.7500	.500	.875	1/4-20
MR-072	FR-072			1.187	
MR-073	FR-073			1.375	
MR-101	FR-101	1.0000	.625	.875	1/4-20
MR-102	FR-102			1.187	
MR-103	FR-103			1.375	
MR-150	FR-150	1.5000	1.000	1.125	5/16-18
MR-151	FR-151			1.375	
FR-152		1.5000	1	1.625	5/16-18

NOTE: Grind stock is provided on the FEMALE interlock surface. To register the interlock on the tapered surfaces, stock must be ground from the front face of the female until there is a slight clearance between the faces of the male and female when assembled. PRECISION FITTING of interlocks requires grinding the necessary amount of stock from the female face to obtain contact on tapered surfaces AND male and female faces simultaneously.

There is a grind stock on the back of both male and female interlocks. After fitting the front taper the backs of the interlocks are ground to match mold plate thickness or to meet design requirement.

Shoulder Plates For Tapered Interlocks

- Required for use with round tapered interlocks
- FHCS Included
- Black Oxide surface finish



Shoulder Plates are designed to work specifically with Tapered Round Interlocks. Tapered Round Interlocks provide positive alignment between mold halves. These locks are manufactured from 4140 steel and are hardened and precision ground to ensure interchangeability. Tapered Round Locks maintain alignment of the mold while allowing for thermal expansion.

SPECIFICATIONS

Material Type	4140
Hardness	48 - 52 Rc
Unit of Measure	Inch

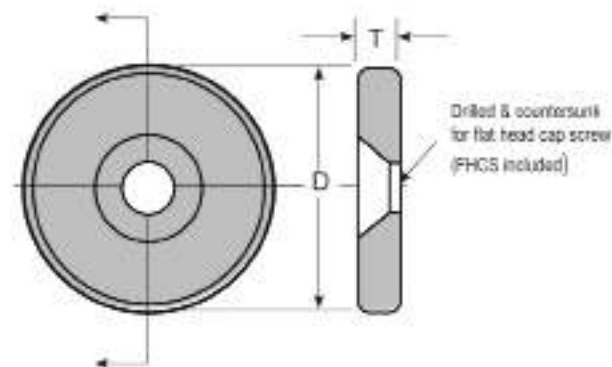

CATALOG NO.	O.D. +.000 / - .005	D DIAMETER	T THICKNESS +.000 / -.002	MOUNTING SCREW SIZE
SP-05	1/2	11/16	3/16	10-24
SP-07	3/4	1	3/16	1/4-20
SP-10	1	1-3/16	3/16	1/4-20
SP-15	1-1/2	1-11/16	1/4	5/16-18