

THE PROPERTY OF THE DRAWING IS ESTABLISHED BY LAW. IT IS FORBIDDEN TO PRODUCE OR SHOW IT TO THIRD PARTY, WITHOUT A WRITTEN AGREEMENT.

Object Number	Name	QTY
1	05.01.001.01	1
2	05.01.001.02	1
3	05.01.001.05	1
4	05.01.001.06	2
5	05.01.75.01	1
6	05.01.100.02	1
7	M.12x100	1
8	R.14.SCH	2

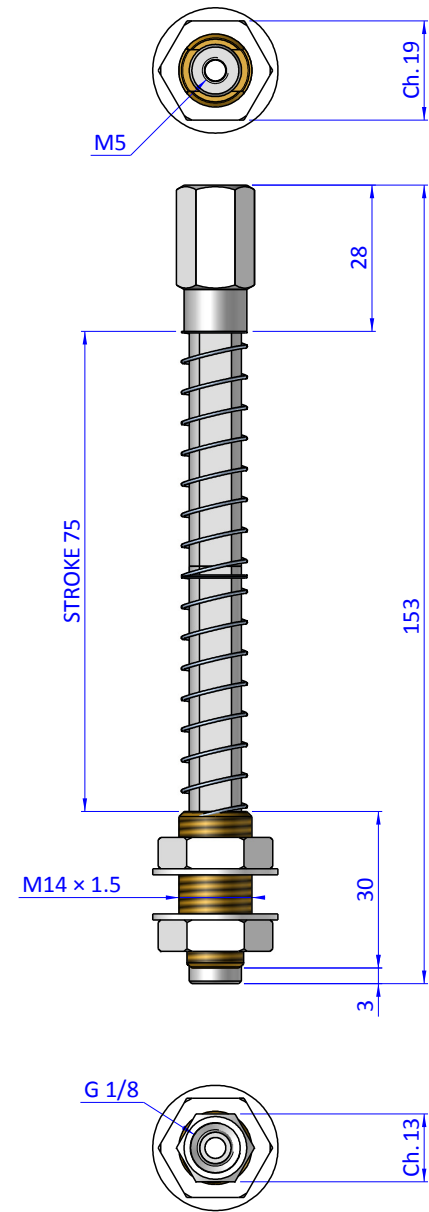
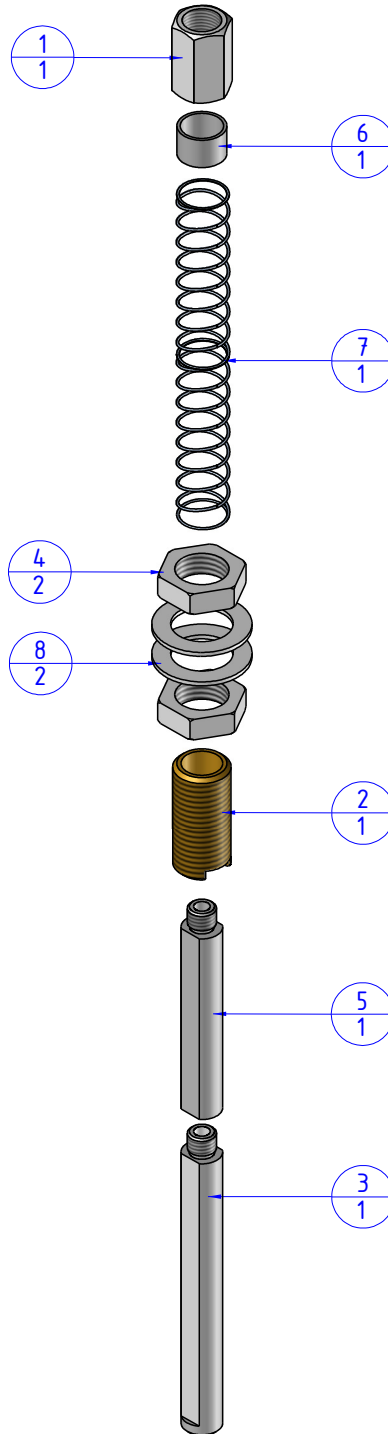

Format A3

UNI 936-76

		DESIGNED FROM		REVIEW
		FPSERVICES		A
GENERAL TOLERANCE		DATE	WEIGHT	
UNI - ISO 2768		13/02/2019	0,102kg	
CLASSE f		CODE		
		CA.05.01.75		CA.05.01.75