



**CATALOGO**

CATALOG  
CATALOGUE  
CATÁLOGO  
KATALOG

 **MASS INTERNATIONAL**  
Belt conveyors



Quando **L'ESPERIENZA** incontra la **TECNOLOGIA**

# when **EXPERIENCE** meet **TECHNOLOGY**

Quand l'expérience rencontre la technologie

Cuando la experiencia se encuentra con la tecnología

Wo Erfahrung und Technologie sich begegnen

# INDEX

**NP**

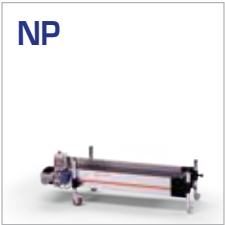

p10

**NI**



p11

**NC**



p12

**NS**



p13

**ND**



p14

**SRA**



p20

**SR-TVR**



p21

**CT**



p22

**NV**



p23

**MV**



p24





**NDS**



p15

**NDZ**



p16

**NCRS**



p17

**NPS**



p18

**NPP**



p19

**MVP**



p25

**SR - M/A**



p26

**Accessories**

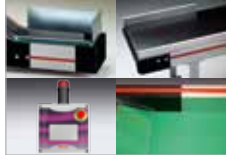

p27

**Worldwide**



p28



 **MASS INTERNATIONAL**  
Belt conveyors

MASS INTERNATIONAL, fondata nel 1988 è una dinamica realtà imprenditoriale con ventennale esperienza nella progettazione e produzione di nastri trasportatori, separatori, miscelatori e magazzini automatici destinati al settore dello stampaggio di materie plastiche, alimentare, farmaceutico.

MASS INTERNATIONAL, founded in 1988 is a dynamic business with twenty years experience in the design and manufacture of conveyors, separators, mixers and automatic storage systems allocated to the sector of the molding plastics, food, pharmaceutical.

MASS INTERNATIONAL, fondée en 1988, est une entreprise dynamique avec vingt ans d'expérience, dans la conception et la production de tapis transporteurs, séparateurs, mélangeurs, et magasins automatiques, destinés aux secteurs de l'industrie plastique, alimentaire et pharmaceutique.

MASS INTERNATIONAL, fundada en el 1988 es una realidad empresarial dinámica con más de veinte años de experiencia en el diseño y producción de cintas transportadoras, separadores, mezcladores y almacenes automáticos destinados al sector de la inyección de materias plásticas, alimentaria y farmacéutica.

MASS INTERNATIONAL gegründet im Jahr 1988 ist ein dynamisches Unternehmen mit 20 Jahren Erfahrung in der Entwicklung und Herstellung von Förderbändern, Abscheidern, Mischern und automatischen Lagersystemen bestimmt für die Verarbeitung von Kunststoffen, Nahrungsmitteln und pharmazeutische Materialien.

# COMPANY





 **MASS INTERNATIONAL**  
Belt conveyors





# PRODUCTION



MASS INTERNATIONAL, con una vasta gamma di nastri trasportatori piani, inclinati, curvi, fissi o snodati, curvi rovesci o speciali prodotti su misura ha la soluzione ideale per ogni vostra esigenza. Materie prime, qualità dei prodotti, magazzino ricambi in grado di assicurare una veloce manutenzione ordinaria e straordinaria dei nastri, alta formazione del personale e capacità di intervento rapido, unite ai servizi di consulenza, montaggio, assistenza tecnica sono il vero valore aggiunto dell'impresa.

MASS INTERNATIONAL, with a wide range of plane, inclined, curved fixed or articulated, reverse curved belts conveyor or special customized products has the ideal solution for all your needs. Raw materials, product quality, spare parts warehouse able to ensure a fast ordinary and extraordinary maintenance of the conveyors, high staff training and rapid response capacity, combined with consulting services, installation, technical assistance are the added value of the company.

MASS INTERNATIONAL, avec une vaste gamme de tapis transporteurs: plats, inclinés, incurvés, fixes ou articulés, incurvations doubles ou produits spéciaux sur mesures, a la solution idéale pour chacune de vos exigences. Grâce à la matière première, la qualité de nos produits, notre magasin de pièces de rechanges, nous sommes capable d'assurer une maintenance rapide. La formation technique de haut niveau du personnel permet une intervention rapide, combinée à un service de conseil, d'installation et d'une assistance technique sont les vraies valeurs ajoutées de l'entreprise.

MASS INTERNATIONAL, con una amplia gama de cintas transportadoras planas, inclinadas, curvas, fijas o articuladas, curvas superiores o productos especiales sobre petición tiene la solución ideal para cualquier exigencia. Materias primas, calidad de los productos, almacén de recambios que pueden asegurar un rápido mantenimiento ordinario y extraordinario de nuestras cintas, alta formación del personal y capacidad de rápida intervención, unidas a los servicios de asesoramiento, montaje, y asistencia técnica son el verdadero valor añadido de la empresa.

MASS INTERNATIONAL mit einer umfangreiche Produktpalette an Förderbändern, Horizontalförderbändern, Steilförderbändern, Winkelförderbändern, gebogene, feste oder gelenkige Förderbändern oder spezielle Förderbändern nach Kundenwunsch, MASS INTERNATIONAL hat die ideale Lösung für alle Ihre Anforderungen. Rohstoffe, die Qualität der Produkte, Ersatzteillager die eine schnelle reguläre sowie außergewöhnliche Wartung und Reparatur der Förderbändern ermöglichen, geschultes Fachpersonal und schnelle Einsatzfähigkeit, im Bereich Beratung, Installation, technischen Support sind die Vorteile des Unternehmens.

# NP

## NASTRO PIANO

FLAT BELT

TAPIS DROIT

CINTA PLANA

ABLAGEFÖRDERBAND

Nastro da porre sotto la pressa per l'estrazione dei pezzi stampati.

This belt is to be placed under the press for extracting the pressing.

Tapis à placer sous la presse pour l'évacuation des pièces injectées.

Cinta transportadora para colocar debajo de las prensas para plástico.  
Para la extracción de las piezas ya estampadas.

Höhenverstellbares Ablageförderband. Aufgrund der Bauweise  
der Seitenwände, besteht ein guter Ausfallschutz für gefertigte Teile.

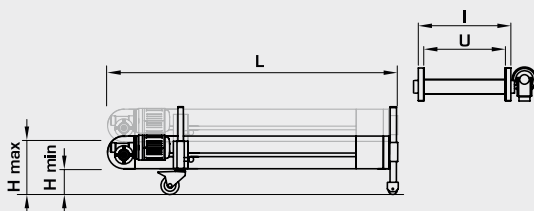

Mod.	L	U	I	H min	H max
NP1	1500	250	305	200	400
NP2	1500	350	405	200	400
NP3	1500	450	505	200	400

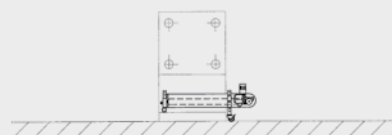

Posizione del nastro perpendicolare alla pressa.  
Perpendicular position of the conveyor respect the moulding machine.  
Tapis posé perpendiculairement à la presse.  
Posición de la cinta en perpendicular a la máquina.  
Que zur Spritzgussmaschine aufgestelltes Förderband.

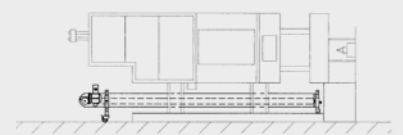

Posizione del nastro parallelo alla pressa.  
Parallel position of the conveyor respect the moulding machine.  
Tapis posé latéralement à la presse.  
Posición de la cinta en paralelo a la máquina.  
Seitlich der Spritzgussmaschine aufgestelltes Förderband.

# NI

## NASTRO INCLINATO

SLANTING BELT  
TAPIS INCLINÉ  
CINTA INCLINADA  
STEILFÖRDERBAND

Questo nastro posto parallelamente o perpendicolarmente alla pressa, consente di avere il materiale stampato in un unico punto di raccolta.

This belt, which is placed parallelly or perpendicularly to the press, allows to collect the pressings in only one place.

Ce Tapis placé parallèlement ou perpendiculairement à la presse permet d'avoir les pièces en un point de récupération unique.

Esta cinta transportadora se coloca paralelamente o perpendicolarmente a la prensa, de modo que se reune todo el material estampado en un unico lugar de recogida.

Höhenverstellbares Steilförderband mit einstellbarem Winkel.

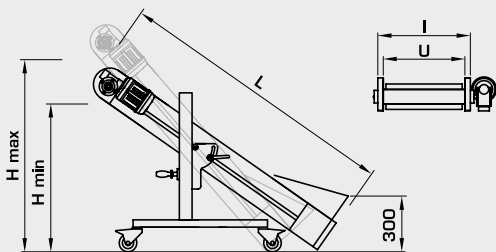

Mod.	L	U	I	H min	H max
NI1	1500	250	305	600	1000
NI2	1500	350	405	600	1000
NI3	1500	450	505	600	1000
NI4	2000	250	305	800	1400
NI5	2000	350	405	800	1400
NI6	2000	450	505	800	1400
NI7	2500	250	305	1000	1800
NI8	2500	350	405	1000	1800
NI9	2500	450	505	1000	1800

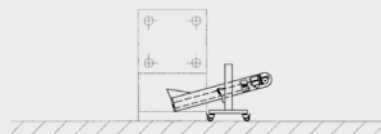

Posizione del nastro perpendicolare alla pressa.  
Perpendicular position of the conveyor respect the moulding machine.  
Tapis posé perpendiculairement à la presse.  
Posición de la cinta en perpendicular a la máquina.  
Que zur Spritzgussmaschine aufgestelltes Förderband.

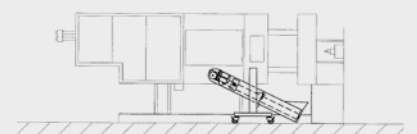

Posizione del nastro parallelamente alla pressa.  
Parallel position of the conveyor respect the moulding machine.  
Tapis posé latéralement à la presse.  
Posición de la cinta en paralelo a la máquina.  
Seitlich der Spritzgussmaschine aufgestelltes Förderband.

# NC

## NASTRO CURVO FISSO

CURVED FIXED BELT  
TAPIS INCLINÉ FIXE  
CINTA CURVA  
WINKELFÖRDERBAND FEST

Nastro da affiancare parallelamente alla pressa, dal lato operatore o nel retro della pressa.

This belt is to be placed next to the press in parallel, either on the operator's side or on the back of the press.

Tapis à placer parallèlement à la presse côté opérateur ou opposé.

Cinta transportadora para ecoplar e prensas para plástico, bien por la parte del operador o por la parte trasera de la prensa.

Winkelförderband mit nicht verstellbarem Winkel für das Aufgabeteil. Universell einsetzbar.

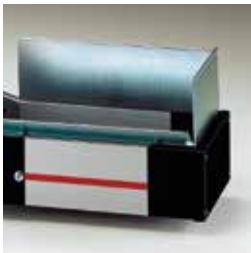

Sovrasponde laterali  
Lateral extra side wall

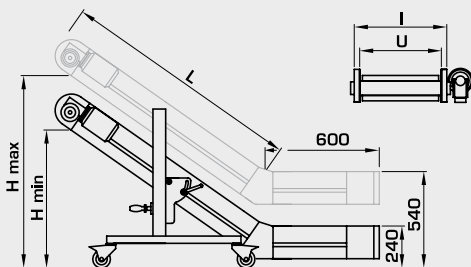

Mod.	L	U	H min	H max
NC1	1300	250	750	1050
NC2	1300	350	750	1050
NC3	1300	450	750	1050
NC4	1800	250	1050	1350
NC5	1800	350	1050	1350
NC6	1800	450	1050	1350

Quote riferite con inclinazione a 35°  
Reported dimensions with 35° inclination  
Dimensions rapportées avec inclinaison 35°  
Dimensiones referidas con inclinación cinta de 35°  
Berichtete Dimensionen mit Neigung 35°

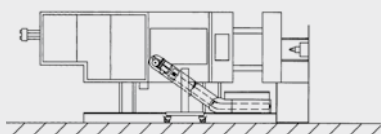

Posizione del nastro parallelo alla pressa.  
Parallel position of the conveyor respect the moulding machine.  
Tapis posé latéralement à la presse.  
Posición de la cinta en paralelo a la máquina.  
Seitlich der Spritzgussmaschine aufgestelltes Förderband.

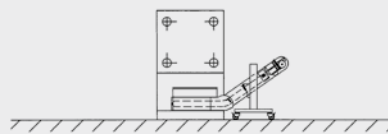

Posizione del nastro perpendicolare alla pressa.  
Perpendicular position of the conveyor respect the moulding machine.  
Tapis posé perpendiculairement à la presse.  
Posición de la cinta en perpendicular a la máquina.  
Que zur Spritzgussmaschine aufgestelltes Förderband.

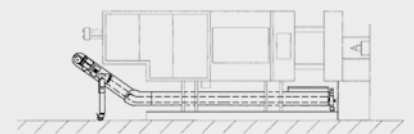

Posizione del nastro interno alla pressa.  
Conveyor inside of the moulding machine.  
Tapis posé à l'intérieur de la presse.  
Posición de la cinta dentro de la máquina.  
In die Spritzgussmaschine integriertes Förderband.

# NS

## NASTRO CURVO SNODATO

CURVED ARTICULATED BELT  
TAPIS INCLINÉ ARTICULÉ  
CINTA ARTICULADA  
WINKELFÖRDERBAND

Nastro multifunzioni. La sua posizione é variabile a seconda delle esigenze di produzione.

Multipurpose belt. Its position may be changed according to the production needs.

Tapis multifonctions. Sa position est variable et s'adapte aux exigences de la production.

Cinta transportadora multifuncion. Su posicion es variable dependiendo de las exigencias de la produccion.

Höhenverstellbares Winkelförderband mit einstellbarem Winkel. Universell einsetzbar.

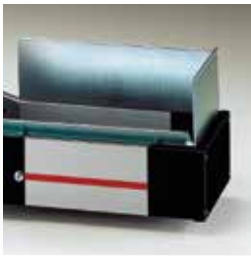

Sovrasponde laterali  
Lateral extra side wall

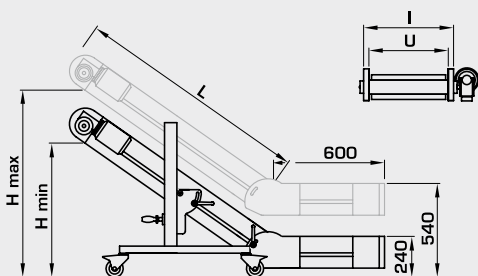

Mod.	L	U	I	H min	H max
NS1	1300	250	305	750	1050
NS2	1300	350	405	750	1050
NS3	1300	450	505	750	1050
NS4	1800	250	305	1050	1350
NS5	1800	350	405	1050	1350
NS6	1800	450	505	1050	1350

Quote riferite con inclinazione a 35°  
Reported dimensions with 35° inclination  
Dimensions rapportées avec inclinaison 35°  
Dimensiones referidas con inclinación cinta de 35°  
Berichtete Dimensionen mit Neigung 35°

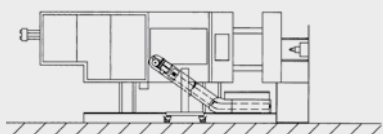

Posizione del nastro parallelo alla pressa.  
Parallel position of the conveyor respect the moulding machine.  
Tapis posé latéralement à la presse.  
Posición de la cinta en paralelo a la máquina.  
Seitlich der Spritzgussmaschine aufgestelltes Förderband.

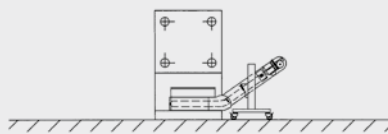

Posizione del nastro perpendicolare alla pressa.  
Perpendicular position of the conveyor respect the moulding machine.  
Tapis posé perpendiculairement à la presse.  
Posición de la cinta en perpendicular a la máquina.  
Que zur Spritzgussmaschine aufgestelltes Förderband.

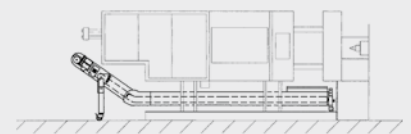

Posizione del nastro interno alla pressa.  
Conveyor inside of the moulding machine.  
Tapis posé à l'intérieur de la presse.  
Posición de la cinta dentro de la máquina.  
In die Spritzgussmaschine integriertes Förderband.

# ND

## NASTRO CURVO DOPPIO FISSO CON SEPARATORE A PALETTE

DOUBLE CURVED FIXED BELT  
TAPIS DOUBLE INCLINAISON  
FIXE CINTA DOBLE

Z-FÖRDERBAND FEST MIT INTEGRIERTEM SEPARIERER

Nastro da affiancare alla pressa. Monta di serie il separatore a palette.

This belt is to be placed next to the press.  
A blade separator is assembled as standard equipment.

Tapis à double inclinaison à placer à côté de la presse.

Cinta transportadora para colocar debajo de las prensas para plástico.  
Para la extracción de las piezas ya estampados.

Höhenverstellbares Z-Förderband mit nicht einstellbarem Winkel.  
Serienmäßig mit Paddelseparierer.

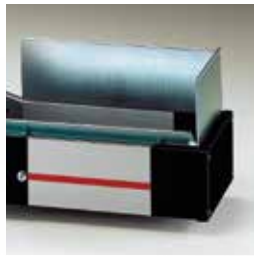

Sovrasponde laterali  
Lateral extra side wall

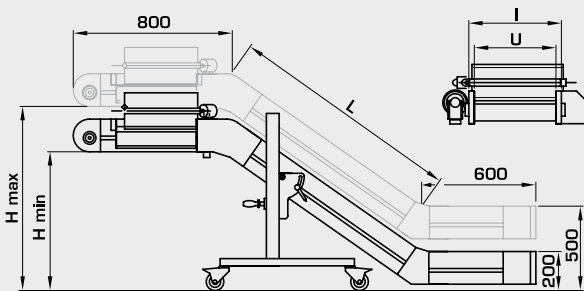

Mod.	L	U	I	H min	H max
ND1	1300	250	305	700	1000
ND2	1300	350	405	700	1000
ND3	1300	450	505	700	1000
ND4	1800	250	305	1000	1300
ND5	1800	350	405	1000	1300
ND6	1800	450	505	1000	1300

Quote riferite con inclinazione a 35°  
Reported dimensions with 35° inclination  
Dimensions rapportées avec inclinaison 35°  
Dimensiones referidas con inclinación cinta de 35°  
Berichtete Dimensionen mit Neigung 35°

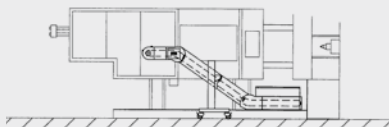

Posizione del nastro parallelo alla pressa.  
Parallel position of the conveyor respect the moulding machine.  
Tapis posé latéralement à la presse.  
Posición de la cinta en paralelo a la máquina.  
Seitlich der Spritzgussmaschine aufgestelltes Förderband.

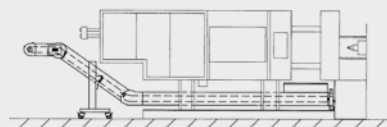

Posizione del nastro interno alla pressa.  
Conveyor inside of the moulding machine.  
Tapis posé à l'intérieur de la presse.  
Posición de la cinta dentro de la máquina.  
In die Spritzgussmaschine integriertes Förderband.

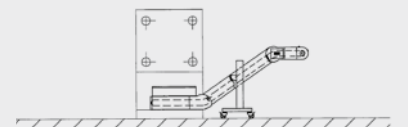

Posizione del nastro perpendicolare alla pressa.  
Perpendicular position of the conveyor respect the moulding machine.  
Tapis posé perpendiculairement à la presse.  
Posición de la cinta en perpendicular a la máquina.  
Que zur Spritzgussmaschine aufgestelltes Förderband.

# NDS

## NASTRO CURVO DOPPIO SNODATO CON SEPARATORE A PALETTE

DOUBLE CURVED ARTICULATED BELT  
TAPIS DOUBLE INCLINAISON ARTICULÉ  
CINTA DOBLE ARTICULADA  
EINSTELLBARES Z-FÖRDERBAND  
MIT INTEGRIERTEM SEPARIERER

Nastro da affiancare alla pressa. Monta di serie il separatore a palette.

This belt is to be placed next to the press.  
A blade separator is assembled as standard equipment.

Tapis à double inclinaison à côté de la presse.

Cinta transportadora para colocar debajo de las prensas para plástico.  
Para la extracción de las piezas ya estampadas.

Höhenverstellbares Z-Förderband mit einstellbarem Winkel.  
Serienmäßig mit Paddelseparierer.

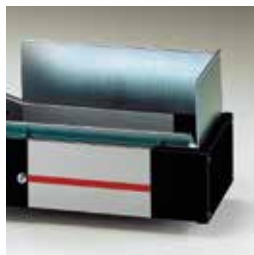

Sovrasponde laterali  
Lateral extra side wall

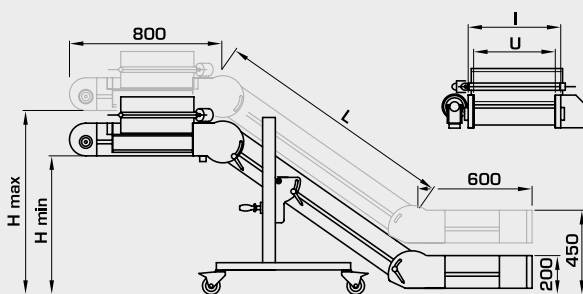

Mod.	L	U	I	H min	H max
NDS1	1300	250	305	700	1000
NDS2	1300	350	405	700	1000
NDS3	1300	450	505	700	1000
NDS4	1800	250	305	1000	1300
NDS5	1800	350	405	1000	1300
NDS6	1800	450	505	1000	1300

Quote riferite con inclinazione a 35°  
Reported dimensions with 35° inclination  
Dimensions rapportées avec inclinaison 35°  
Dimensiones referidas con inclinación cinta de 35°  
Berichtete Dimensionen mit Neigung 35°

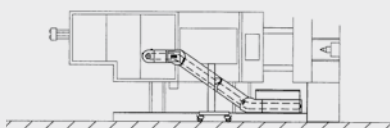

Posizione del nastro parallelo alla pressa.  
Parallel position of the conveyor respect the moulding machine.  
Tapis posé latéralement à la presse.  
Posición de la cinta en paralelo a la máquina.  
Seitlich der Spritzgussmaschine aufgestelltes Förderband.

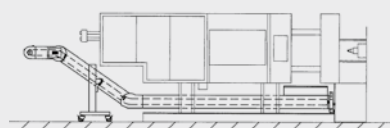

Posizione del nastro interno alla pressa.  
Conveyor inside of the moulding machine.  
Tapis posé à l'intérieur de la presse.  
Posición de la cinta dentro de la máquina.  
In die Spritzgussmaschine integriertes Förderband.

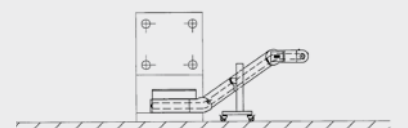

Posizione del nastro perpendicolare alla pressa.  
Perpendicular position of the conveyor respect the moulding machine.  
Tapis posé perpendiculairement à la presse.  
Posición de la cinta en perpendicular a la máquina.  
Que zur Spritzgussmaschine aufgestelltes Förderband.

# NDZ

## NASTRO CURVO DOPPIO SNODATO

DOUBLE CURVED CONVEYOR

TAPIS DOUBLE INCLINAISON ARTICULÉ

CINTA CURVA DOBLE ARTICULADA

EINSTELLBARES Z-FÖRDERBAND

Nastro da posizionare a fianco della pressa o sotto la pressa. Atto a trasportare i pezzi su scatole o tavoli di lavoro. Non comprende il separatore a palette.

Conveyor to place at the side of the injection moulding machine or under the injection moulding machine, suitable to transport parts in box or on working table. This model don't include the flap separator.

Tapis à placer soit à côté de la presse soit sous la presse. Ce tapis est utilisé pour le convoyage des pièces dans des cartons ou sur des tables de travail (Il est fourni sans séparateur à palette).

Cinta para posicionar al lado de la máquina o bajo la inyectora. Adecuada para transportar las piezas a las cajas o las mesas de trabajo. No incluye el separador de paletas.

Z- Förderband mit verstellbarem Winkel. Serienmäßig ohne Paddelseparierer.

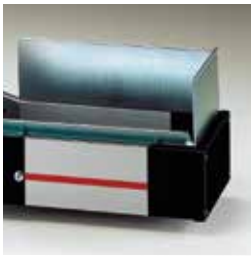

Sovrasponde laterali  
Lateral extra side wall

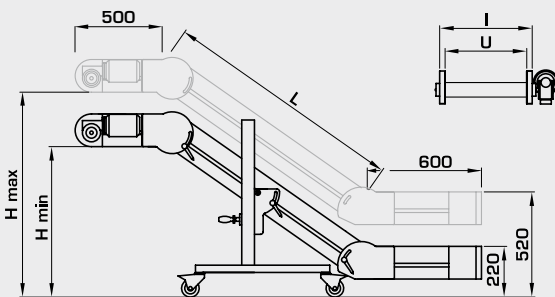

Mod.	L	U	I	H min	H max
NDZ1	1300	250	305	700	1000
NDZ2	1300	350	405	700	1000
NDZ3	1300	450	505	700	1000
NDZ4	1800	250	305	1000	1300
NDZ5	1800	350	405	1000	1300
NDZ6	1800	450	505	1000	1300

Quote riferite con inclinazione a 35°  
Reported dimensions with 35° inclination  
Dimensions rapportées avec inclinaison 35°  
Dimensiones referidas con inclinación cinta de 35°  
Berichtete Dimensionen mit Neigung 35°

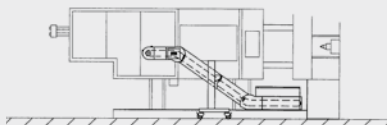

Posizione del nastro parallelo alla pressa.  
Parallel position of the conveyor respect the moulding machine.  
Tapis posé latéralement à la presse.  
Posición de la cinta en paralelo a la máquina.  
Seitlich der Spritzgussmaschine aufgestelltes Förderband.

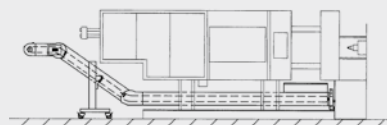

Posizione del nastro interno alla pressa.  
Conveyor inside of the moulding machine.  
Tapis posé à l'intérieur de la presse.  
Posición de la cinta dentro de la máquina.  
In die Spritzgussmaschine integriertes Förderband.

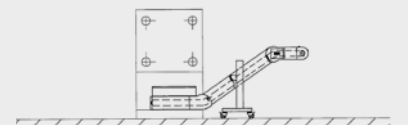

Posizione del nastro perpendicolare alla pressa.  
Perpendicular position of the conveyor respect the moulding machine.  
Tapis posé perpendiculairement à la presse.  
Posición de la cinta en perpendicular a la máquina.  
Que zur Spritzgussmaschine aufgestelltes Förderband.



# NCRS

## NASTRO CURVO ROVESCIO SNODATO

FLEXED REVERSE CURVED CONVEYOR

TAPIS ARTICULÉ RENVERSÉ

CINTA CURVA AL REVÉS ARTICULADA

ABGEWINKELTES ENTNAHMEFÖRDERBAND

Nastro a bordo pressa per trasporto pezzi depositati da robot e trasferimento su piano di lavoro o contenitori.

Side injection moulding machine conveyor to transport pieces released from the robot and to convey the pieces on a working table or in containers.

Tapis a positionner à côté de la presse pour le convoyage de pièces déposées par robot, utilisé aussi pour le transport de pièces sur plan de travail ou dans des containers.

Cinta sobre máquina para transporte de piezas depositadas desde el robot y transportadas hasta el plano de trabajo o contenedores.

Im Winkel verstellbares, abgewinkeltes Förderband. Geeignet zur Roboterablage und zur Zuführung der Teile auf Arbeitshöhe oder in den Transportbehälter.



A richiesta: protezione  
Optional: protection guard

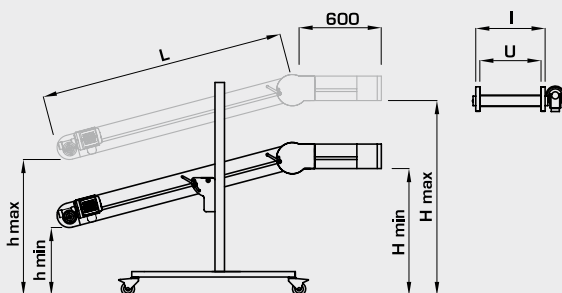

Mod.	L	U	I	h min/h max	H min/H max
NCRS1	1800	350	405	500/1000	1000/1500
NCRS2	1800	450	505	500/1000	1000/1500
NCRS3	1800	550	605	500/1000	1000/1500
NCRS4	1800	650	705	500/1000	1000/1500
NCRS5	2500	350	405	500/1000	1300/1800
NCRS6	2500	450	505	500/1000	1300/1800
NCRS7	2500	550	605	500/1000	1300/1800
NCRS8	2500	650	705	500/1000	1300/1800

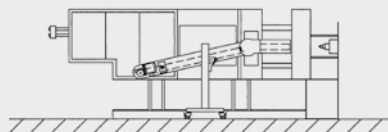

Posizione del nastro parallelo alla pressa.  
Parallel position of the conveyor respect the moulding machine.

Tapis posé latéralement à la presse.  
Posición de la cinta en paralelo a la máquina.  
Seitlich der Spritzgussmaschine aufgestelltes Förderband.

# NPS

## NASTRO PIANO SENZA SPONDE

FLAT CONVEYOR BELT WITHOUT PROTECTIONS

TAPIS PLAT SANS RIVES

CINTA PLANA SIN LATERALES

ABLAGEFÖRDERBAND OHNE SEITENWÄNDE

• Sponde laterali riportate • Guide laterali regolabili  
Nastro piano a bordo pressa da usare per scarico da robot o come piano di montaggio pezzi.  
Lunghezza e larghezza a richiesta.

• Auxiliary side wall • Adjustable side wall  
Flat conveyor to place at the side of the injection moulding machine to use to discharge the pieces from the robot or it is possible to use like parts assembling moving table. Special length and width available per request.

• Rives latérales rapportées • Rives latérales réglables  
Tapis plat à coté de la presse pour dépose robot ou pour convoyage pièces (longueur et largeur mesure).

• Bordas laterales superpuestos • Guías laterales regulables  
Cinta plana sobre máquina para usar para la descarga de robot o plano de montaje de piezas.  
Largo y ancho según pedido.

• Auswechselbare Seitenbleche • Seitlich verstellbare  
Höhen- und Neigungsverstellbares Ablageförderband ohne Seitenwände, auf Wunsch zusätzliche Seitenbleche integrierbar.

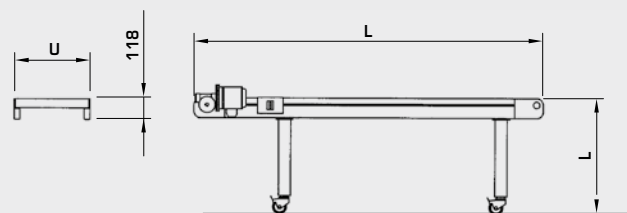

Guide laterali regolabili  
Adjustable lateral side guides



Sponde riportate  
High fixed bring lateral sidewalls

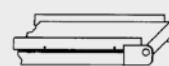

# NPP

## NASTRO PIANO CON PROTEZIONI

FLAT CONVEYOR BELT WITH PROTECTIONS

TAPIS PLAT AVEC PROTECTIONS

CINTA PLANA CON PROTECCIONES

ABLAGEFÖRDERBAND MIT SCHUTZUMHAUSUNG

Nastro piano a bordo pressa collegamento a robot. Con protezione in policarbonato o rete metallica zincata. Completo di quadro elettrico con consenso esterno. Avanzamento temporizzato del nastro.

Side injection moulding machine conveyor; with connection with the robot and polycarbonate protection or zincplated metallic net, with electric box with outside signal and step by step timer.

Tapis plat à coté de la presse pour dépose robot avec protection en polycarbonate ou protection grillagée, équipé d'un coffret électrique avec contact externe pour robot, avance temporisée ou marche continu.

Cinta plana sobre máquina con conexión a robot. Con protecciones en policarbonato o red metálica cincada, con cuadro eléctrico con autorización externa del avance temporizado de la cinta.

Ablageförderband, mit Schutzumhausung in Polycarbonat oder verzinktem Drahtzaun zur Einhaltung der Sicherheitsvorschriften beim Einsatz von Ablagerobotern und automatisierten Anlagen. Externe Ansteuerung der Bandbewegung integriert.



Protezione con tettuccio:  
Lato Dx - Sx  
Protection guard with roof:  
Right side - left Side



### A richiesta:

- Misure del nastro
- Consenso esterno
- Fotocellula fine nastro
- Segnalatore luminoso/ acustico
- Porta ispezione su protezione

### Optional:

- Conveyor with special dimensions
- External consent
- End conveyor sensor
- Light-acoustic signal
- Inspection door install on the protection

### Pour réalisation sur mesure:

- Dimensions du tapis
- Contact externe
- Photocellule en bout de tapis
- Alarme lumineuse ou sonore
- Porte d'inspection sur les protections

### Sobre pedido:

- Medidas de la cinta
- Contacto externo
- Fotocélula al final de la cinta
- Señal luminosa/ acustica
- Puerta para inspección sobre las protecciones

### Auf Wunsch:

- Abmasse des Förderbandes
- Externe Freigabe
- Fotozelle am Bandende
- Leuchtanzeige oder akustisches signal
- Abdeckung mit Zugriffklappe

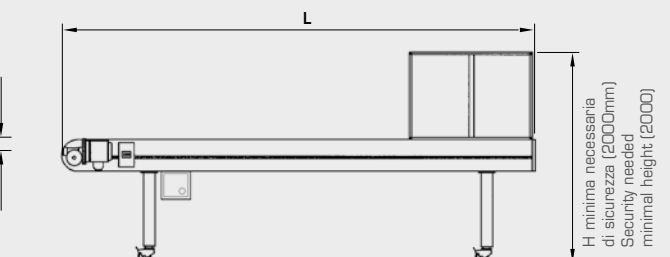
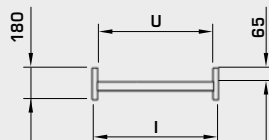
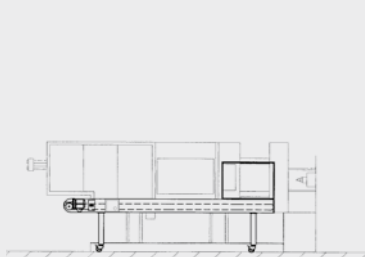

# SRA

## SISTEMA RIEMPIMENTO AUTOMATICO A PIU' LIVELLI E TRASLAZIONE CONTENITORI

MULTILEVEL AUTOMATIC FILLING SYSTEM  
AND CONTAINERS TRANSLATION  
SISTEMA DE LLENADO AUTOMÁTICO A MÁS  
NIVELES Y TRASLADO CONTENEDORES  
AUTOMATISCHES ABLAGESYSTEM  
MIT INTEGRIEREN LIFT

- linea riempimento automatico
- sistema di pesatura su richiesta
- costruzione personalizzata su richiesta
- carico scatole con nastro o con robot
- automatic filling line
- weighing system on request
- customised construction, on request
- box loading by conveyor or by robot
- Ligne de remplissage automatique
- Système de pesage sur demande
- Construction personnalisée sur demande
- Chargement des boites par tapis convoyeur ou robot
- línea de llenado automático
- sistema de pesaje, a solicitud
- construcción personalizada, a solicitud
- Cargadas cajas con cinta o robot
- automatische Abfüllanlagen
- Wägesysteme auf Anfrage
- kundenspezifische Konstruktion auf Anfrage
- Beladung der Box durch das Förderband oder den Roboter

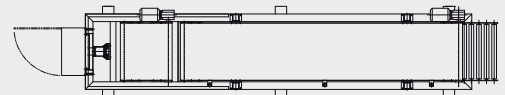
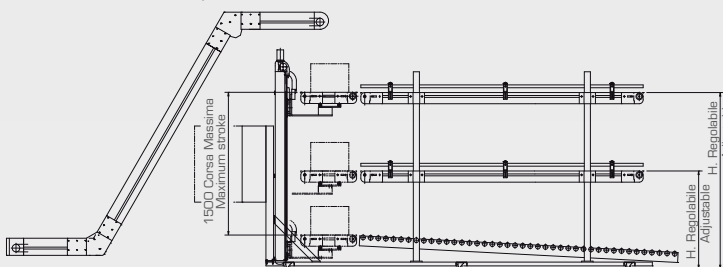
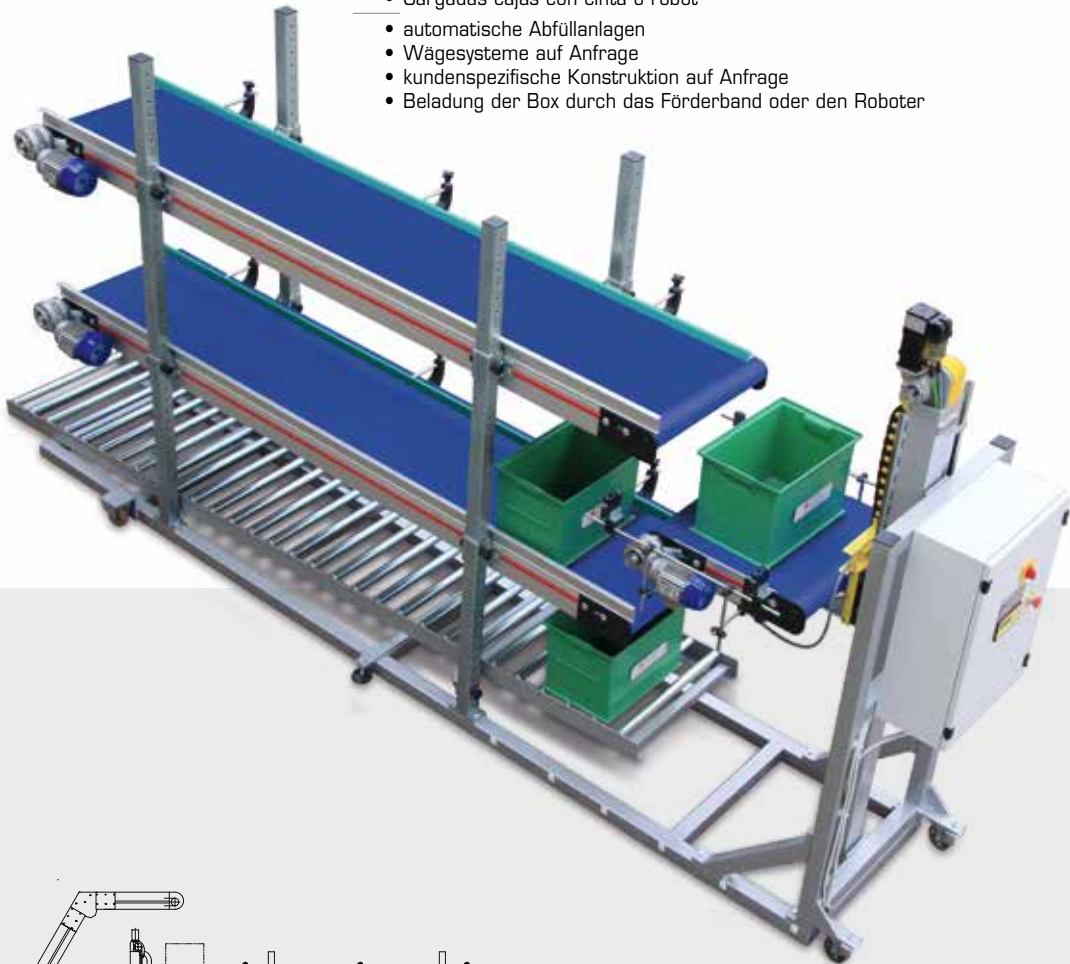

# SR TVR

## SR - SCIVOLO ROTANTE

ROTATING SLIDE  
TOBOGGAN ROTATIFS  
TOBOGÁN GIRATORIOS  
DREHRUTSCHE

## TVR - TAVOLA ROTANTE

ROTATING TABLE  
TABLE ROTATIFS  
MESA GIRATORIOS  
RUNDTISCH

Tavola e scivolo rotante per carico sacchi scatole con movimento rotatorio programmabile.

Rotating table and slide for the feeding of bags and boxes with fully programmable rotating movement.

Table et toboggan rotatifs pour le chargement de sacs et cartons avec une rotation programmable.

Mesa y tobogán giratorios para la carga de sacos y cajas con movimiento rotatorio programmable.

Rundtisch und Drehrutsche zur Befüllung von Beuteln oder Kartons, mit programmierbarer Drehbewegung. Drehtisch auch in zweistöckiger Version lieferbar.



### SR

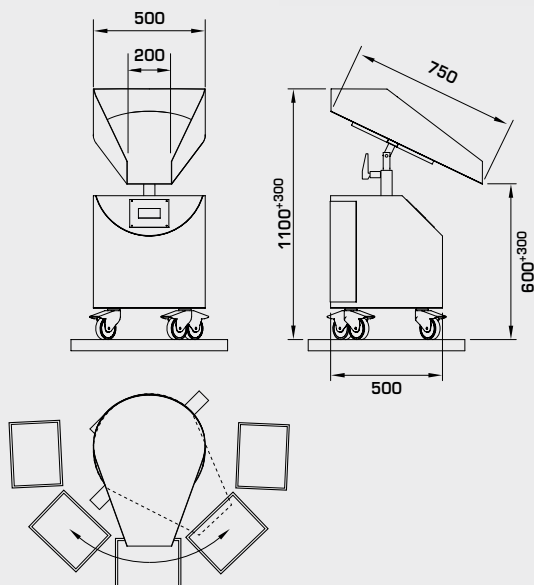

### TVR

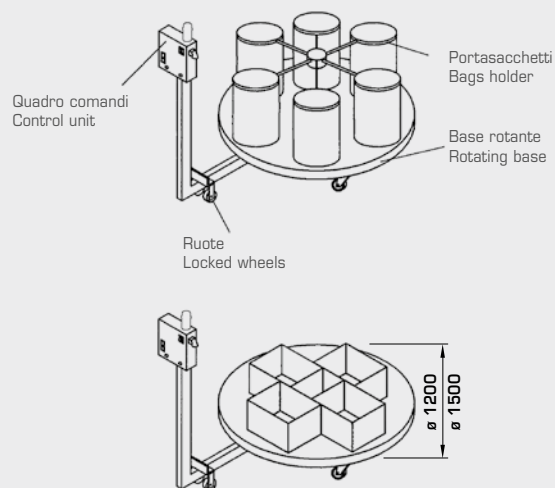

Diametro tavola rotante 1200/1500mm  
Rotating table diameter 1200/1500mm

# CT

## CONTENITORI

MATERIAL CONTAINERS

CONTENEURS

CONTENEDORES

BEHÄLTER

Fusti in acciaio inox per stoccaggio materiale.

Stainless steel bin for material storage.

Container en acier inox pour le stockage de matériaux.

Recipientes en acero inox para el almacenamiento del material.

Behälter aus rostfreiem Stahl für die Materiallagerung.



Mod.	Ø	H	Capacità litri/kg Capacity litres/kg	Materiale Material
80/50	400	900	80/50	INOX
180/100	570	900	180/100	INOX
230/120	570	1030	230/130	INOX

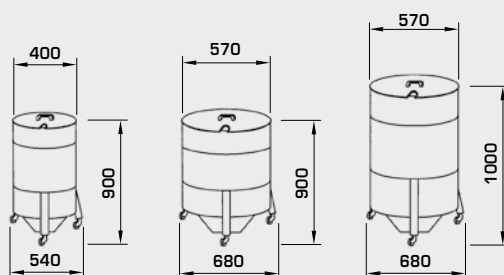

# NV

## NASTRO CON VASCA PER RAFFREDDAMENTO

BELT WITH COOLING TANK

TAPIS AVEC BAC DE REFROIDISSEMENT

CINTA TRANSPORTADORA CON REFRIGERACION

BAND MIT KÜHLUNGSWANNE

Utilissimo per pezzi di medio e grosso spessore. Evita il ritiro brusco del materiale.

It is very useful for parts having a medium and a great thickness. It prevents the sudden shrinkage of the material.

Très utile pour les pièces d'épaisseur moyenne ou importante. Evite les retraits de matière.

Util para piezas de mediano y grueso espesor. Evita la contraccion brusca del material. Avance controlado y velocidad variable.

Sehr nützlich für Teile mittlerer und großer Dicke. Verhindert die bruske Materialschrumpfung.



Mod.	U	I
NV1	250	360
NV2	350	460
NV3	450	560
NV4	250	360
NV5	350	460
NV6	450	560
NV7	250	360
NV8	350	460
NV9	450	560

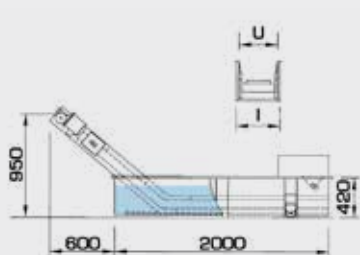

NV1 - NV2 - NV3  
Nastro vasca particolari non galleggianti  
Conveyor with cooling tank for no floating parts



NV4 - NV5 - NV6  
Nastro vasca particolari galleggianti  
Conveyor with cooling tank for floating parts



NV7 - NV8 - NV9  
Nastro vasca particolari galleggianti e non galleggianti  
Conveyor with cooling tank for floating and no floating parts

# MV

## MISCELATORE

MIXER

MÉLANGEUR

MEZCLADORES

CHARGENMISCHER

Ottimo per la miscelazione del materiale, sostituisce i vecchi fusti. Pratico il sistema di aspirazione del materiale da portare alla macchina operatrice. Miscelatori a bordo pressa completi di quadro elettrico (rotazione continua o rotazione temporizzata). Micro di sicurezza su porta di carico e scarico parte inferiore del miscelatore.

It is excellent for mixing the material; it replace the old drums. It is equipped with a practical system which sucks the material to be transferred to the machine tool. Side machine mixers with electrical box (continuous rotation or with timer) and security switches installs on the charging door and on the discharging door placed on the lower part of the mixer.

Mélangeur équipé d'un coffret de commande soit en continu, soit temporisé. Micro de sécurité sur porte de remplissage supérieure et de déchargement partie inférieure du mélangeur.

Optimo para la mezcla de todo de materiales. Mezcladores sobre Máquina Completos de cuadro eléctrico (rotación continua o rotación temporizada). Micro de seguridad sobre puerta de carga y descarga por parte inferior del mezclador.

MV Mischer zur vollständigen Durchmischung des gesamten Kunststoffgranulates. Fahrbar auf Rollen, kann direkt neben der Spritzgießmaschine installiert werden. Steuerung erfolgt über eine am Mischer angebrachte Schalttafel, Intervall- und Dauerminen einstellbar. Entnahme erfolgt über seitliche Absaugöffnung. Sicherheitsschalter an Einlassdeckel und Ablasschieber gewährleisten die Arbeitssicherheit.



Mod.	L	H	Capacità litri/kg Capacity litres/kg	Materiale Material
MV1	700x700	1050/1250	200/120	INOX
MV2	700x700	1050/1250	200/120	FERRO
MV3	800x800	1200/1400	330/200	FERRO
MV4	600x600	900/1100	110/70	FERRO
MV5	600x600	900/1100	110/70	INOX
MV6	800x800	1200/1400	330/200	INOX

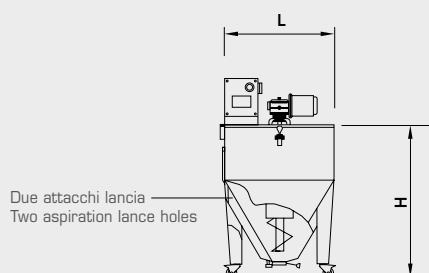



# MVP

## MISCELATORE GRANDE

MIXER  
MÉLANGEUR  
MEZCLADORES  
MISCHER



Miscelatori per medie e grandi quantità di materiale, funzionali ed economici per miscelazione di diversi materiali.

Mixers for middle and big quantity of material, functionally and economical for the mixing of different materials and powders.

Mélangeurs fonctionnels et économiques pour moyennes et grandes quantités.

Mezcladores para medias y grandes cantidades de material, funcionales y económicos para la mezcla de distintos materiales.

Funktionelle und wirtschaftliche Mischer für mittlere und grosse Materialmengen.

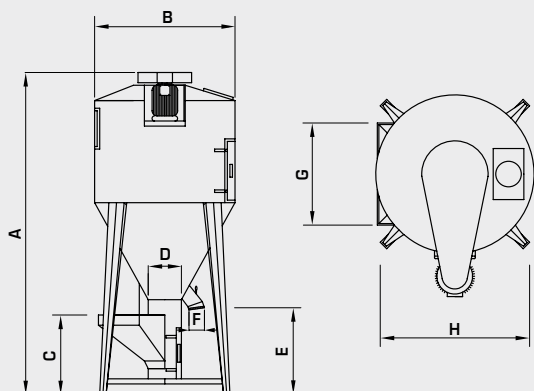

Litri Litres	Quantità Kg Quantity Kg	HP	A	B	C	D	E	F	G	H	Peso Kg Weight Kg
500	350	3	2550	850	600	200	800	150	650	1150	250
1000	600	5,5	3050	1060	650	280	800	200	750	1250	320
1800	1000	7,5	3200	1400	700	320	800	230	950	1400	450
2500	1500	7,5	3500	1500	700	320	800	230	950	1450	480
3500	2000	10	3900	1600	700	320	800	230	950	1500	600
5000	3000	10	4200	1900	750	320	800	230	1000	1800	800
8000	4800	10	4600	2350	750	320	800	230	1000	1950	1070
10000	6000	15	5100	2350	750	320	800	230	1000	1950	1200
14000	8000	15	5700	2450	750	320	800	230	1000	2150	1350
16000	10000	20	6200	2450	750	320	800	230	1000	2150	1500
20000	12000	25	7100	2450	900	400	900	230	1100	2150	2000

# SR-M/A

## SEPARATORE ROTANTE

DRUM SEPARATOR  
SÉPARATEUR ROTATIF  
SEPARADOR ROTATIVO  
TROMMELSEPARIERER

Separazione pezzi di misure contenute tramite rulli rotanti. Regolazione rulli a modalità manuale o automatica.

Separation of small products by rotating rollers. Setting of the rollers by manual or automatic.

Séparateur pour pièces de petites dimensions, par rouleaux rotatifs. Réglage des rouleaux en mode manuel ou automatique.

Separador para piezas de pequenas dimensiones, por rodillos rotativos. Arreglo de los rodillos en modo manual o automático.

Durch die Rotation der Trommel, werden die Teile und Angüsse mit unterschiedlichen Größen bewegt und getrennt. Der Abstand der Rollen kann sowohl automatisch, als auch manuell eingestellt werden.



Mod.	L	L1	L2	H
SR-M	720	450	1300	1200
SR-A	720	500	1300	1200

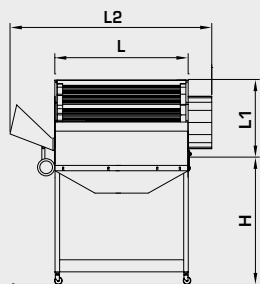

**SEPARATORI**  
SEPARATORS  
SÉPARATEURS  
SEPARADORES  
DE COLADA  
ABSCHIEDER



**SRS - SRD - SRT**  
Separatore a rullo  
semplice, doppio e triplo  
Simple roller separator,  
Double and Triple

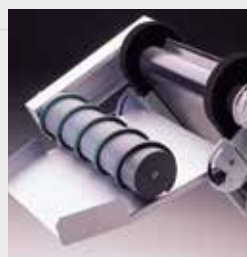

**SS**  
Separatore a spirale  
Spiral separator



**SP**  
Separatore a palette  
Paddle separator

# Accessori

ACCESSORIES  
ACCESSOIRES  
ACCESORIOS  
ZUBEHÖRE

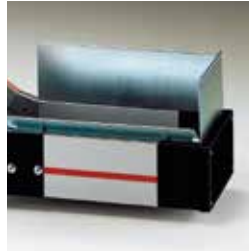

**NC - NS - ND - NDS**  
**Sovrasponde laterali**  
Lateral extra side wall



**NPS**  
**Sponde riportate**  
High fixed bring lateral sidewalls



**NPS**  
**Guide laterali regolabili**  
Adjustable lateral side guides



**Variatore di velocità elettronico**  
Electronical speed variator by frequency inverter



**Quadro elettrico programmabile**  
Programmable electric control

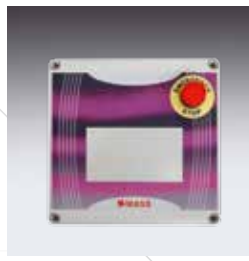

**Quadro elettrico star-stop**  
On/off electric control



**Salvatore star-stop singolo**  
Standard on/off control unit single



**Salvatore star-stop doppio**  
Standard on/off control unit double



**G5FL**  
**Tela alta resistenza**

G5FL  
Heavy duty belt



**FDA**  
**Tela alimentare blu liscia**

FDA  
Blue smooth belt for food industry



**FDA**  
**Tela alimentare bianca con listelli**

FDA  
White smooth belt + flights for food industry



**GP**  
**Bugnato**

GP  
Supergrip belt



**PU**  
**Spondaflex**

PU  
Spondaflex belt

# WORLDWIDE



MEXICO

MO

CHILE

PERÙ

ARGENTINA



**MASS INTERNATIONAL**

Belt conveyors

MASS INTERNATIONAL, con una rete di vendita e propri distributori presenti in più di venti paesi in tutta Europa, Australia, America Latina e Africa, è il partner ideale ed affidabile per la vostra azienda che mira a collocarsi come punto di riferimento importante del settore.

MASS INTERNATIONAL, with a sales network and distributors in over twenty countries throughout Europe, Australia, Latin America and Africa, is the ideal and reliable partner for your company that aims to position itself as important benchmark in the industry.

MASS INTERNATIONAL, avec son réseau de vente et ses propres distributeurs présents dans plus de vingt pays: Europe, pays de l'Est, Australie, Amérique Latine et Afrique, est le partenaire idéal et fiable pour une entreprise qui vise à se positionner en tant que point de référence important dans l'industrie.

MASS INTERNATIONAL, con una red de ventas y distribuidores en exclusiva está presente en más de veinte países en toda Europa-Paises del Este, Australia, América Latina y África. Es el partner ideal y de confianza para vuestra empresa que trata de colocarse como punto de referencia importante del sector.

MASS INTERNATIONAL mit einem Netz von Vertriebsbüros und Distributoren in mehr als 20 Ländern in Europa, Osteuropa, Australien, Lateinamerika und Afrika, ist der ideale und zuverlässige Partner für Ihr Unternehmen. MASS INTERNATIONAL ist eine wichtige Referenz der Branche.



# notes

---

---

---

---

---

---

---

---

---

---

---

---

---

---

---

---

---

---

---

---

---

---

---

---

---

---

---

---

---





# **MASS INTERNATIONAL**

## **Belt conveyors**

MASS INTERNATIONAL Srl  
Via Ponte Poscola, 20 - Loc. GHISA  
36075 MONTECCHIO MAGGIORE (VI)

Tel. 0444 607292  
Fax 0444 607349

[www.massinternational.it](http://www.massinternational.it)  
[info@massinternational.it](mailto:info@massinternational.it)  
[sales@massinternational.it](mailto:sales@massinternational.it)  
[dir@massinternational.it](mailto:dir@massinternational.it)